

Zetriuslita et al., 2018

Volume 4 Issue 2, pp. 726-742

Date of Publication: 23<sup>rd</sup> August 2018

DOI-<https://dx.doi.org/10.20319/pijss.2018.42.726742>

This paper can be cited as: Zetriuslita, & Wahyudin, J. (2018). *Mathematical Communication Ability and Curiosity Attitude through Problem based Learning and Cognitive Conflict Strategy based on Academic Level: A Study in Number Theory*. PEOPLE: International Journal of Social Sciences, 4(2), 726-742.

This work is licensed under the Creative Commons Attribution-NonCommercial 4.0 International License. To view a copy of this license, visit <http://creativecommons.org/licenses/by-nc/4.0/> or send a letter to Creative Commons, PO Box 1866, Mountain View, CA 94042, USA.

## **MATHEMATICAL COMMUNICATION ABILITY AND CURIOSITY ATTITUDE THROUGH PROBLEM BASED LEARNING AND COGNITIVE CONFLICT STRATEGY BASED ON ACADEMIC LEVEL: A STUDY IN NUMBER THEORY**

**Zetriuslita**

*FKIP Universitas Islam Riau, Jl. Kaharuddin Nasution No.113 Marpoyan Pekanbaru, Indonesia*  
[zetri.lita@gmail.com](mailto:zetri.lita@gmail.com)

**Wahyudin, Jarnawi**

*Postgruade School in Universitas Pendidikan Indonesia Bandung, Indonesia*  
[wahyudin+mat@yahoo.com](mailto:wahyudin+mat@yahoo.com)  
[jarnawi@upi.edu.com](mailto:jarnawi@upi.edu.com)

---

### **Abstract**

*The aim of this research is to examine the achievement and improvement of students' Mathematical Communication Ability (MCA) and Curiosity Attitude (CA) through Problem-Based Learning Model and Cognitive Conflict Strategy (PBLCCS) and Explicit Direct Instruction (EDI). Adopting a quasi-experimental mixed method with pretest-posttest control group design and sequential explanatory strategy, the study population consists of undergraduate students of Mathematics Education Study Program at a private Islamic University in Riau of Sumatra Indonesia, academic year 2015/2016 in course subject of Number Theory. Quantitative data were collected from essay tests, questionnaires and interview sheets whereas observation sheets were used to generate qualitative data. The findings show that there*

*is (1) no difference in Mathematical Communication Ability (MCA) between students taught by Problem-Based Learning and Cognitive Conflict Strategy (PBLCCS) and Explicit Direct Instruction (EDI) based on academic levels (high, medium, low); (2) no difference in Mathematical Curiosity Attitude (CA) between those who have been taught by PBLCCS and EDI based on academic levels (high, medium, low) despite students' mistakes in mathematical communication; (3) PBLCCS has not been able to improve students' curiosity in learning mathematics; (4) Worksheet cannot optimally improve students' MCA and CA.*

### **Keywords**

Mathematical Communication, Mathematical Curiosity, Problem-Based Learning, Cognitive Conflict Strategy, Constructivist

---

## **1. Introduction**

Communication ability is considered necessary in our real life, as many misleading incidents are often caused by miscommunication or misinterpretation of received information. Look at this simple incident as example. When someone tells us that certain area has been under fire and then we directly call the fire brigade without further clarification, we may end up in trouble as the fire fighters have come for nothing. For this reason, information should be received properly and then reacted accurately. Similarly, this communication skill is also essential in mathematics learning. Misinterpretation of mathematical information, either in oral or written form, may lead to misleading results. Therefore, communication ability is urgently needed in all aspects of life, particularly in the process of mathematics learning.

At primary and secondary education, besides logics, communication ability is an important part in mathematics and mathematics education. In mathematics learning, students' mathematical communication ability can be identified when, upon understanding certain mathematical concepts, they can explain the concepts correctly, either in oral or written form (NCTM 2000).

Furthermore, Litmann & Spielberger (2003) as cited in (Reio et.al, 2006) mathematics learning also relates to curiosity. In this context, it is defined as students' motivation to acquire new information and knowledge as well as sensorial experience which can stimulate behavior to seek new information. This curiosity is actually nature to human in which they want to know something by asking 'what is this?' or 'why this happens this or that way?'. Along with development task, these curiosity-based questions develop into more sophisticated ones such as

‘how some phenomena/problems happen?’ and ‘how to solve these problems?’. In fact, these questions begin to appear in humans as early as childhood when children start talking to express their feelings (Santoso, 2011). Another scholar argues that curiosity is marked by human efforts to seek and explore something so that they feel enthusiastic to learn, find out and investigate (Suhandak, 2014).

This argument is also supported by another scholar, humans’ curiosity is identifiable from their willingness to learn, investigate, and know something (McElmeel, 2002). Curiosity is also important to develop in learning as it is an essential part of motivation (Shellnut, 1996). In addition, that the reason why curiosity is important in learning is because it can support and build students’ knowledge (Elliott et al, 2000) in (Suhandak, 2014) As such, developing students’ curiosity should become the main goal of their learning. It is believed that the higher the students’ curiosity on something, the closer they are to their learning environment, including their learning groups (Binson, 2009)

The development of mathematical curiosity relates to learning method. Developing students’ critical thinking and mathematical curiosity relies on a relevant learning method so that they can stimulate and develop these skills properly. One of which is called Problem-Based Learning Model and Cognitive Conflict Strategy (PBLCCS) which is the focus of this study. The role of teachers is to facilitate students’ thinking and learning, therefore, teacher should attempt to motivate students to learn. To be aware of teaching practice activities done by teachers, we should have enough knowledge about learning and teaching methods. (Lessani et.al (2016).

One purpose of Problem-Based Learning Model and Cognitive Conflict Strategy (PBLCCS) is that students can solve problems related to their cognitive conflict. Problems presented should be able to challenge and arouse students’ curiosity to find solutions, and not make them desperate when searching for the solution. In this vein, a study on comprehension ability and mathematical communication in cognitive conflict-based cooperative learning concludes that classrooms using this strategy is considered more effective than the conventional ones (Zulkarnain, 2013). In relation to mathematical curiosity, another study found that the implementation of conceptual understanding procedures model can improve students’ mathematical curiosity on concept understanding (Ismawati et.al, 2014).

Based on the aforementioned theories and some previous research findings, it is argued that these selected learning strategies can enhance some abovementioned students’ cognitive abilities. On the basis of this, the study proposes the following hypotheses:

1. There is a difference in learning achievement and improvement of mathematical critical thinking ability of students who are exposed to PBLCCS and those who are given Explicit Direct Instruction (EDI).
2. There is a difference in learning achievement and improvement of mathematical curiosity of students who are exposed to PBLCCS and those who are given Explicit Direct Instruction (EDI).

## **2. Literature Review**

### **2.1 Problem Based Learning (PBL)**

Problem-Based Learning (PBL) started in medical education at the Faculty of Medicine, McMaster University of Canada in the midst of 1960s. It then developed in the Netherlands and Australia (Camp, 1996). Theoretically, PBL is based on Piaget's constructivist and Vygotsky's socio-constructivist learning. Piaget claimed two main biological principles which can develop humans' intellectual; adaptation and internal organization (Orey 2010).

To be able to survive, humans need to adapt themselves to physical and mental stimuli they receive. He argued that knowledge is constructed when learners organize different experiences which consist of mental structure and schemata. With this cognitive constructivist, Piaget claimed that the development of human beings has four stages; sensorial motor, pre-operational, concrete and formal operation (Suparno, 2006). Constructivist approach to learning promotes active participation from students. This suggests that students are taking control of learning by "interacting" with the learning materials. In a constructivist classroom, students come equipped with prior knowledge (Jowati, 2017)

Meanwhile, Vygotsky's social constructivist, well-known for his Zone Proximal Development (ZPD), states that learners can neither be freed to work on their own nor be fully supported, but in between these two sides. ZPD is the basis for scaffolding components of cognitive process. At this point, scaffolding refers to various methods we can apply to obtain optimum metacognitive control. These two constructivist theories underlie the PBL in this study (Arends, 2007). Constructivist approaches, with their focus on student-centered learning, have long advocated student involvement in the process of gaining knowledge and have sought ways for teachers to become advocates in the learning process rather than as figures who only dictate information (Sukhla, A, 2015).

## **2.2 Cognitive Conflict Strategy (CCS)**

Cognitive strategy is defined as a mental procedure used to achieve various cognitive goals ranging from the most basic goal like sensing to the most sophisticated ones such as observing, retrieving and remembering, imagining and thinking (Surya, 2015). Cognitive strategy refers to the process of identifying and solving certain problems whereas cognitive conflict refers to different perceptions (opinions) which lead to a conflict between two different groups. Furthermore, a conflict may also occur within individuals who feel uncertain when they have to take one or more choices (Bruner, 1971; Gagne, 1985) in (Surya, 2015).

These cognitive strategy and cognitive conflict are combined into cognitive conflict strategy, which belongs to constructivist learning. Piaget's constructivist theory states that when people build their knowledge, they need assimilation in the form of effective cognitive conflict to adjust old concept to new experience so that they can construct higher knowledge equilibrium (Woolfolk, 1984). To complete this, Piaget believes that learners should actively reorganize their stored knowledge in their cognitive structure through assimilation and accommodation.

In addition, assimilation and accommodation are two separate but related processes. Assimilation is a process in which the incoming information to the brain is appropriately adjusted to meet its structure. Meanwhile, accommodation is the changing process of brain structure caused by observation or new information so that the new information can fit in (Santrock, 2012). Furthermore, in relation to this, Santrock explains two phases of learning for concept change; assimilation and accommodation. During assimilation, learners use their existing concepts to face the new phenomena whereas during accommodation, they change irrelevant concepts to adjust to the new information or phenomenon they are facing.

In learning, cognitive conflict needs stimulation to create a more effective and meaningful assimilation process. For this reason, cognitive conflict strategy is necessarily required in mathematics learning strategy. Since cognitive conflict strategy is believed to be more frequently identified in personal than collaborative contexts, collaboration is an opportunity for students to solve their individual (personal) conflicts. Cognitive conflict stimulation in learning makes the process of assimilation more effective and meaningful in students' intellectual discourse. Therefore, cognitive conflict strategy is necessarily required in mathematics learning strategy (Dahlan, 2012) as this study focuses. Furthermore, cognitive conflict strategy has a common pattern, which includes *exposing alternative framework*, *creating conceptual cognitive*, and *encouraging cognitive accommodation* (Ismaimuza, 2010)

### 2.3 Problem Based Learning (PBL) and Conflict Cognitive Strategy (PBLCCS)

In addition to PBL, cognitive conflict strategy (CCS) can also reinforce the critical thinking skills of learners. Based on the steps PBL and CCS, then a combination of both steps is compiled and named the Problem Based Learning Cognitive Conflict Strategy (PBLCCS), which has 5 steps as follows:

1. Orientation of the problem (conflict identification)
  - a. Giving students a problem which has conceptual challenge (a cognitive conflict) which leads to *disequilibrium* among students.
  - b. Directing students to relate the newly received information to the background knowledge they have obtained (assimilation).
  - c. Identifying if students agree or disagree with the new information given (accommodation).
2. Learning group organization
3. Individual and in-group supervision
  - a. Students understand the given problem on their own.
  - b. Lecturer facilitates students in solving the given problem.
  - c. High achieving students help their low achieving peers complete the assigned conflict.
4. Work development and presentation
  - a. A few group representatives present the result of their group works.
  - b. Non-presenting groups are given opportunity to ask and comment on the presentation.
5. Analysis and evaluation of the process of solving a given problem or conflict

### 2.4 Mathematical Communication Ability (MCA)

How a communication or message gets to the receiver is illustrated by Shannon, C.E (1948) dan Shannon, C.E and Weaver, W (1949) in the following diagram:

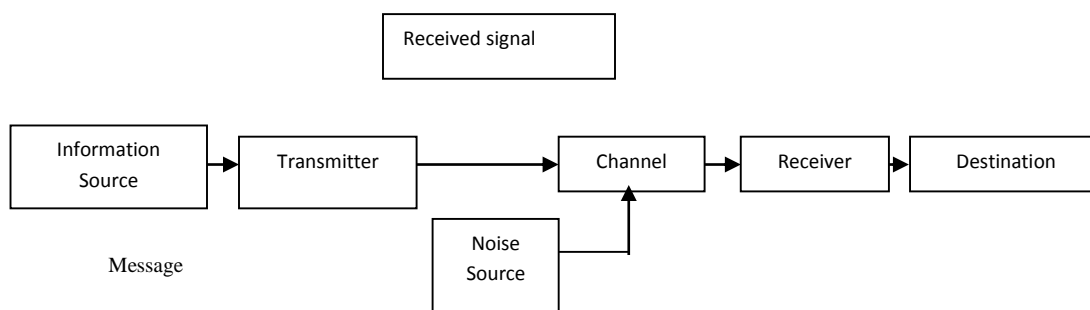

**Figure 1:** Communication path from source of information up to recipient

In order for communication to run properly, needed a tool. The main tool in communication is the language. Kusumah (2008) suggests that through communication, mathematical ideas can be exploited in a variety of perspectives, students 'way of thinking can be sharpened, understanding growth can be measured, learners' thinking can be consolidated and organized, mathematical knowledge and problem-building learners can be constructed, Learners can be improved, and community learners can be formed (Rohana, 2015).

About mathematical communication, Freitas (2012) said that mathematical communication is a way of sharing ideas and clarifying comprehension. Through communication, ideas become objects of reflection, improvement, discussion and amendment. When learners are challenged to communicate their thoughts to others, either orally or in writing, learning becomes clear, sure and appropriate in using the language of mathematics (NCTM, 2000).

## **2.5 Mathematical Curiosity Attitude (CA)**

In addition to Problem-Based Learning and Cognitive Conflict Strategy (PBLCCS), this study also discusses Mathematical Curiosity Attitude (CA) as an important aspect in learning success. According to Binson (2009), curiosity is a tendency to inquire, investigate and find out more after having knowledge about something. It is also the tendency to inquire, investigate, and seek a framework to think about curiosity about something more deeply. This high desire for knowing something or looking for answers to certain questions is the catalyst for developing someone's science abilities, including students of mathematics education. Litmann and Spielberger (2003) as cited in Reio et.al (2006) states that curiosity is the desire to acquire new information and knowledge, as well as a new sensory experience that can motivate behavior to find out more.

In addition, Santoso (2011) also argues that curiosity or a desire to know something is the basic nature of humans who keep asking whatever they see and find before asking why or how something happens. These questions then continue and develop into more advance ones by asking why a problem occurs, how something happens and how to find solution to this problem. Such these critical questions are typical to human beings and can be identified from the very beginning they can talk and express their feelings to other humans.

### **3. Method**

#### **3.1 Research Design**

This study adopts a quasi-experimental design which mixes both quantitative and qualitative data in a sequential explanatory strategy (Creswell,2010). Quantitative and qualitative data were separately analyzed to answer two different research questions. To provide a more comprehensive analysis, as research design shows, the main data in this study is quantitative whereas qualitative data serve as complementary.

#### **3.2 Participants**

The population of the study is students of third semester, majoring in mathematics education, academic year 2015/2016, five parallel classes (3A-E) at a private Islamic university in the province of Riau, Sumatera, Indonesia. Using random cluster sampling, the study selected class 3A as experiment group exposed to PBLCCS and class 3B as control group taught by EDI.

#### **3.3 Data Collection**

##### **3.3.1 Instruments**

The study has both quantitative and qualitative instruments. The first includes essay test about communication skill and questionnaire on learner's curiosity attitude and the second is interview.

About communication test is developed from indicators as follows :

1. Write down ideas, situations, reasons and relationships in solving mathematical problems;
2. Using exact terms, tables, diagrams, notations, or mathematical formulas;
3. Explain / ask about mathematics
4. Understand, interpret, and evaluate mathematical ideas in the form of writing and in other visual forms.
5. Revisit a description into its own language.

Meanwhile, the questionnaire is developed from Suhandak (2014), McElmeel (2002), (Binson, 2009), which has some indicators as follow:

1. Inquiry about information or a given problem
2. Desire and want to find out details
3. Enthusiasm/motivation in learning
4. Search for information from various sources
5. Trial of alternative problem solving



### 3.3.2 Data Analysis

Quantitative data were analyzed using statistical descriptions, *t-test*, *Mann-Whitney U-test* (normal distribution of data), *one-way ANOVA*, *Kruskal-Wallis-test* (when data are not normally distributed). To determine the increase of students' critical thinking ability and curiosity attitude, the following mathematical formula of normal-gain was used:

$$N\_Gain = \frac{\text{posttest score} - \text{pretest score}}{\text{score maksimum ideal} - \text{pretest score}}$$

(Meltzer, 2002)

Next, the Mann-Whitney U-test was used to analyze data from questionnaire on mathematical curiosity which have ordinal distribution. Finally, both quantitative and qualitative data were collected within three phases of the study; initial, middle and end. Data of test and questionnaire were first collected, followed by data of interviews. These two types of data were then combined to answer the research questions.

## 4. Findings and Discussion

### 4.1 The achievement and improvement of Mathematical Communication Ability (MCA) based on academic level

The achievement and improvement of students' Mathematical Communication Ability (MCA) is recapitulated in Table 1 below.

**Table 1:** *The achievement and improvement of Mathematical Communication Ability (MCA) based on academic level*

Academic Levels	Achievement				Improvement			
	PBLCCS		EDI		PBLCCS		EDI	
	$\bar{x}$	<i>s</i>	$\bar{x}$	<i>s</i>	$\bar{x}$	<i>s</i>	$\bar{x}$	<i>s</i>
High	6.143	2.609	8.143	4.099	0.285	1.464	0.505	0.274
Medium	5.81	3.458	6.333	3.524	0.368	0.207	0.402	0.230
Low	7.857	3.760	8.142	3.236	0.576	0.254	0.489	0.228

Table 1 which comprehensively describes the achievement data of students' MCA based on their academic levels shows that the MCA average achievement of students who were exposed to PBLCCS is lower than those who were taught by EDI. Similarly, overall result also shows that the average MCA achievement of experiment students is lower than those of control group. In addition, improvement data show similar results. The MCA achievement result of students who were exposed to PBLCCS based on academic levels show that they have lower

achievement average than those who were taught by EDI, except for students with low academic level. Meanwhile, the average MCA achievement and improvement of students is not higher than those taught by EDI, based on either academic levels or overall results.

#### 4.2 Statistical test results of MCA achievement and improvement

The statistical test result of students' MCA achievement and improvement can be seen in Table 2 below.

**Table 2:** *t-Test : Test results of students' MCA achievement and improvement based on academic levels*

Academic Levels	Achievement			Improvement		
	<i>t</i>	Sig. (2-tailed)	Notes	<i>t</i>	Sig. (2-tailed)	Notes
High	-1.089	0.298	No difference	-1.430	0.178	No difference
Medium	-0.353	0.727	No difference	-0.374	0.712	No difference
Low	-0.152	0.881	No difference	0.143	0.889	No difference

Table 2 shows that based on academic levels, the obtained value is  $\text{Sig} \geq \alpha$ ,  $H_0$  is accepted but  $H_1$  is rejected. This rejection means that the thesis 'there is a difference in MCA achievement and improvement between students exposed to PBMCCS and EDI' is also rejected. Therefore, it is concluded that in average, there is no difference in MCA achievement and improvement between students in experiment and control groups based on academic levels. This finding implies that PBLCCS has not been able to improve students' MCA in all academic levels; high, medium and low.

Furthermore, student's answer can be seen below.

#### **Indicator of communication ability :**

Rewriting an explanation into your own words

#### **Question 5b**

A student is going to buy a score of school equipment consisting of books and pens with a total amount of IDR 56 (in thousand). The price of a book is 3 (thousand) more than that of a pen and the total money should all be spent up (the number of book purchased is more than that of pen).

- Write some steps required in completing the problem above and check again your answer.
- Explain the obtained answer in your own words.

Based on the two questions above, question 5b can only be answered if students can complete question 5a. In this study, the problem appears when most students have difficulty in answering question 5a so that only some can answer question 5b. A few of them did not answer the question at all, and as such, this indicator has the lowest improvement score. An example of student's answer to question 5b can be seen below.

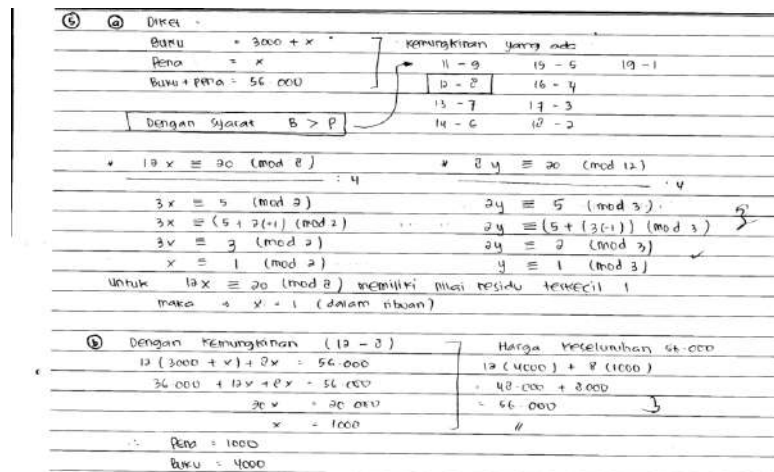

Figure 2: Student's answer for indicator 5 question 5b

Source : student's post-test result

Students' answers to question (5b) depend on their ability to complete question 5a. If students can answer question 5a correctly, they are expected to be able to complete question 5b. However, many students who can answer question 5a still have difficulties in completing question 5b due to their inability to use the required concept or find alternative answer to the question.

Based on student's answers for questions (5 a-b) with indicator of critical thinking and mathematical communication ability which has the lowest average of improvement, the study examines the reasons for this finding through students' interviews as shown in the following dialog.

- Researcher : For question 5b, you have decided to buy 12 books and 8 pens. Why?  
 Student : My answer is based on question 5a. by using PDL and KL, I could get  $x = 12$  and  $y = 8$   
 Researcher : Why didn't you use the requirements that the number of book should be more than pen and the price of a book is IDR 3 (thousand) more than that of a pen.  
 Student : I am not really sure when to use this requirement. Since I have already obtained the value of  $x$  dan  $y$  , I thought I could complete the answer.

- Researcher : That's why you have to use the requirement. Do you have an alternative answer for  $x$  dan  $y$ ? Your answer is correct but not really complete
- Student : Thank you, Mom.

Having analyzed the quantitative data of test and questionnaire as well as qualitative data of interviews, this study concludes that the implementation of PBLCCS has not been able to significantly achieve and improve students' Mathematical Communication Ability (MCA), both based on academic levels and overall result. This relatively low achievement is, among others, caused by the process of mathematics learning which does not emphasize Mathematical Communication Ability (MCA). Furthermore, observational evidence shows that the mathematics learning focused more on the development of students' critical thinking ability and rather ignored their MCA. Another reason for this low average is because most students are not accustomed to communicate with and about mathematics either in oral or written form. The other reason for this low achievement is the minimum role of learning media.

The study found that student' worksheet focuses more on the development of students' critical thinking and does not give enough attention to the improvement of Mathematical Communication Ability (MCA). In addition, the PBLCCS exposed to experiment group is also limited so that they do not have sufficient exposure which enables them to develop and improve their MCA. Within this limited time and exposure, students still adjust themselves to the new learning strategy and have not grasped the 'spirit' of PBLCCS properly. This is supported by who believes that the implementation of Problem-Based Learning will only be effective when it is supported by sufficient and conducive situations. In this case, teachers should find out an alternative way or strategy relevant with students' conditions.

Meanwhile, a teacher-centered learning of EDI strategy with sufficient teacher's explanation enables students to develop their mathematical communication effectively. Both descriptive and inferential analyses show that students who were exposed to EDI have higher average achievement and improvement of MCA than those who were taught by PBLCCS. This assumption is supported by Moreno who concludes that direct instruction accompanied by sufficient exercises allow students to have a deeper learning, leading to a more successful achievement. This finding is also confirmed by the result of another study (Sweller, 2006) which emphasizes that student-centered learning with minimum supervision tend to fail to achieve the expected learning goals or outcomes.

The achievement and improvement of Mathematical Curiosity Attitude (CA) based on academic levels. Data recapitulation of students' MC achievement and improvement are presented in Table 4 below.

**Table 4:** Recapitulation of Students' Mathematical Curiosity Attitude (CA) and Improvement Based on Academic Level

Academic Levels	Achievement				Improvement			
	PBLCCS		EDI		PBLCCS		EDI	
	$\bar{x}$	s	$\bar{x}$	s	$\bar{x}$	s	$\bar{x}$	s
High	111.857	17.257	120.286	12.175	0.285	0.301	0.505	0.274
Medium	115.727	12.174	119.833	16.552	0.368	0.207	0.402	0.230
Low	130.714	16.255	120.000	19.723	0.576	0.254	0.489	0.228

Table 4 about the achievement and improvement of students' Mathematical Curiosity Attitude (CA) based on academic levels shows that the experiment students exposed to PBLCCS have lower achievement and improvement average than those control group exposed to EDI, with the exception of low level. Overall description also shows a similar result. The average CA achievement and improvement of experiment group students exposed to PBLCCS is lower than those in control group taught by EDI. This indicates that the implementation of PBLCCS is only positively effective for students with low academic level.

The statistical test result of students' Mathematical Curiosity achievement and improvement based on academic levels can be found in Table 5 below.

**Table 5:** *t*-Test : The result of achievement and improvement test of students' CA based on Academic level

Academic Levels	Achievement			Improvement		
	<i>t</i>	Sig. (2-tailed)	Notes	<i>t</i>	Sig. (2-tailed)	Notes
High	-1.056	0.312	No difference	0.567	0.581	No difference
Medium	-0.672	0.509	No difference	0.604	0.552	No difference
Low	1.109	0.289	No difference	0.235	0.818	No difference
Overall	-0.259	0.797	No difference	0.851	0.399	No difference

Table 5 shows that based on academic levels, the obtained value of  $\text{Sig} \geq \alpha$ ,  $H_0$  is accepted and  $H_1$  is rejected. This rejection means that the thesis 'there is a difference in Mathematical Curiosity (MC) achievement and improvement between students exposed to PBLMCCS and EDI' is also rejected. Therefore, it is concluded that in average, there is no difference in MC achievement and improvement between students in experiment and control

groups based on their academic levels. This finding implies that PBLCCS has not been able to improve students' MC in all academic levels; high, medium and low.

This result is influenced by many causes. One of them is because most students have already possessed high Mathematical Curiosity (MC) prior to the treatment so that both PBLCCS and EDI do not really influence their mathematical curiosity level. Another reason is ineffective learning media. The worksheet that students used emphasizes the development of critical thinking more than mathematical curiosity. Consequently, their average MC achievement and improvement is not high.

Another reason is limited exposure to PBLCCS. During the relatively short experiment period, students showed unfamiliarity with the new strategy and wasted their time adjusting to it. Since this strategy has never been introduced by other lecturers before, the adjustment process took longer than expected. Students have to understand the assigned problems on their own and completed the tasks within their groups without the intervention of the lecturer. As a result, they have not really grasped the 'spirit' of the PBLCCS within this short treatment period. In contrast, they are accustomed to being spoon-fed by their lecturers in EDI. Teacher-centered allows the teachers/lecturers to provide students with more detailed learning materials and varied exercise so that they feel more curious about mathematics.

This practice is also in line with a local proverb well-known among Minang students, the participants of this study, "*alah bisa karena biasa, pasa kaji dek baulang, pasa jalan dek batampuah*" which in English means "knowing is believing or practice makes perfect and the more you practice the more perfect the result you will get." In addition, Gagne as cited in Rohana (2015) argues that, unlike cognitive domain which is the direct object of mathematics, curiosity is an indirect affective domain in mathematics learning so that students need longer time to acquire and learn. Student's mathematical curiosity have proven this concern, as such, teachers and other educators still need to make harder efforts, to find more creative ways to improve the mathematical curiosity of their students. They should identify ways by which learning autonomy is proportionally supported by teacher's guidance and instruction (Zetriuslita, 2016).

## **5. Conclusions**

Based on data analysis and discussion, it is concluded that on the basis of academic levels:

1. There is no difference in achievement and improvement results of Mathematical Communication Ability (MCA) between students who were exposed to Problem-Based Learning Model with Cognitive Conflict Strategy (PBLCCS) and those who were exposed to Explicit Direct Instruction (EDI).
2. There is no difference in achievement and improvement results of Mathematical Curiosity (MC) between students who were exposed to Problem-Based Learning Model with Cognitive Conflict Strategy (PBLCCS) and those who were taught by Explicit Direct Instruction (EDI).
3. That PBLCCS has not had positive effect on students' MCA achievement and improvement is resulted from the minimum role of students' worksheets in developing their mathematical communication ability. Besides, students are also not accustomed to communicating with and about mathematics.
4. That PBLCCS has not had positive effect on students' Mathematical Curiosity (MC) is caused by high pre-test score. Prior to treatment, students have already had high curiosity level so that the average of their achievement and improvement results is not significant.

## **References**

- Arends. (2007). *Learning To Teach*. Seventh Edition. McGraw Hill Companies. New York.
- Binson, B. (2009). Curiosity Based Learning (CBL) program. *US-China Education Review*. 12 (6):13-22.
- Camp, G.(1996). Problem based learning: A paradigm shift or passing fad? *Medical Education Online*, 1-5. <https://doi.org/10.3402/meo.v1i.4282>
- Creswell. J.W. (2010).*Research design. Qualitative. quantitative and mixed method approaches*. Third Edition. California. (Terjemahan). Achmad Fawaid.
- Dahlan, J. (2012). Implementasi strategi pembelajaran konflik kognitif dalam upaya meningkatkan high order mathematical thinking peserta didik. *Jurnal Pendidikan*. Volume 13. Nomor 2. September 2012. 65-76.
- Freitas, E. D (2012). What were you thinking? a deleuzian/guattarian analysis of communication in the mathematics classroom. *Educational Philosophy and Theory*, 1-21
- Ismaimuza, D (2010). Kemampuan berpikir kritis dan kreatif matematis peserta didik SMP melalui pembelajaran berbasis masalah dengan strategi konflik kognitif. Disertasi pada PPs UPI. Bandung: Not published.

- Ismawati,F, Nugroho, S.E dan Dwijananti, P (2014). Penerapan model pembelajaran conceptual understanding procedures untuk meningkatkan curiosity matematis dan pemahaman konsep peserta didik. *Jurnal Pendidikan Fisika Indonesia* 10 (2014).22-27. doi: 10.15294/jpfi.v10i1.3047.
- Jowati binti Juhary. (2017). Constructivism: The roots of military pedagogy? *PEOPLE: International Journal of Social Sciences* ISSN 2454-5899. The author and GRDS Publishing. All rights reserved. Available Online at: <http://grdspublishing.org>. 3(1), 467 – 480. <https://doi.org/10.20319/pijss.2017.s31.467480>
- Kusumah, Y. (2008). Konsep pengembangan dan implementasi computer based learning dalam meningkatkan kemampuan high order mathematical thinking.
- Lessani, A, Suraya Md. Yunus, & Kamariah, B.A.B (2017). Comparison of new mathematics teaching methods with traditional method. *PEOPLE: International Journal of Social Sciences* ISSN 2454-5899 © 2015. Available Online at: <http://grdspublishing.org/PEOPLE/people.html>, 1285-1297. <https://doi.org/10.20319/pijss.2017.32.12851297>
- McElmeel, S. L. (2002). *Character education: A book guide for teachers, librarians, and parents*. Greenwood Village, Colorado:Greenwood Publishing Group,Inc
- Meltzer (2002). The relationship between mathematics preparation and conceptual learning gains in physics: A possible “hidden variable” in diagnostic pretest scores. *Am. J. Phys.*, Vol. 70, No. 12, December 2002. American Association of Physics Teachers.  
<https://doi.org/10.1119/1.1514215>
- NCTM (2000) *Principles and standards for school mathematics*. USA: The National Councils of Teachers of Mathematics.
- Orey. (2010) *Emerging perspectives on learning. teaching. and technology*. Switzerland. Global Text Project.
- Reio T. J, Petrosko, J.M, Wiswell, A.K, & Thongsukmag, J ( 2006). The measurement and conceptualization of curiosity. *The Journal of Genetic Psychology* 167(2):117-35. doi: 10.3200/ GNTP. 167.2 .117-135.
- Rohana .(2015). Peningkatan kemampuan penalaran da komunikasi matematis serta karakter mahasiswa calon guru melalui pembelajaran reflektif. Disertasi pada Sekolah Pascasarjana Universitas Pendidikan Indonesia. Disertasi tidak diterbitkan.
- Santoso, I. (2011). Mengasah kemampuan berpikir kreatif dan rasa ingin tahu melalui pembelajaran matematika dengan berbasis masalah (Suatu Kajian Teoritis) Prosiding



- Seminar Nasional Matematika dan Pendidikan Matematika Jurusan Pendidikan Matematika FMIPA.UNY. ISBN :978 –979 –16353–6 – 3.
- Santrock (2012). Life-span development. Edisi ke-13. Diterjemahkan oleh Benedictine Widiasinta. Perkembangan Masa Hidup. Erlangga dan Power Macro.
- Shannon, C.E and Weaver, W (1949). The mathematical theory of communication. University of Illinois Press. Urbana and Chicago
- Shannon, C.E. (1948). A mathematical theory of communication. The Bell System Technical Journal, Vol. 27, pp. 379–423, 623–656, <https://doi.org/10.1002/j.1538-7305.1948.tb00917.x><https://doi.org/10.1002/j.1538-7305.1948.tb01338.x>
- Shellnut, B. J. (1996). A motivating influence in the field of instructional systems design. Wayne State University. <http://www.arcsmodel.com/pdf/Biographical%20Information.pdf>
- Suhandak, M. (2014). Keefektifan metode inkuiri dalam pembelajaran sistem persamaan linear dua variabel ditinjau dari prestasi dan curiosity. Indonesian Digital Journal of Mathematics and Education. Volume I Edisi 1 2014 <http://idealmathedu.p4tkmatematika.org>. ISSN 2407-7925.
- Shukla, A. (2015). Constructivism and integration of ICT: powerful blend of teaching – learning process. PEOPLE: International Journal of Social Sciences ISSN 2454-5899 © 2015. Available Online at: <http://grdspublishing.org/PEOPLE/people.html>, 82-90 <https://dx.doi.org/10.20319/pijss.2015.s21.8290>
- Suparno, P. (2006). Filsafat konstruktivisme dalam pendidikan. Yogyakarta :Kanisius
- Surya. (2015). Strategi kognitif dalam proses pembelajaran. Alfabeta Bandung.
- Woolfolk. A.E.(1984). Educational psychology for teachers. New Jersey: Prentice-Hall.Inc
- Zetriuslita (2016). Profil sikap ilmiah rasa ingin tahu (curiosity) matematis mahasiswa. Jurnal Ilmu Pendidikan STKIP Kesuma Negara. ISSN 2085-7144. 8(1), 41-46
- Zulkarnain,I (2013). Kemampuan pemahaman dan komunikasi matematis dalam pembelajaran kooperatif berbasis konflik kognitif. Disertasi pada Sekolah Pascasarjana Universitas Pendidikan Indonesia. Dissertation not published.