

Myint & Soe, 2018

Volume 4 Issue 2, pp. 266-274

Date of Publication: 3rd November, 2018

DOI-<https://dx.doi.org/10.20319/mijst.2018.42.266274>

This paper can be cited as: Myint, C. C. & Soe, M. M., (2018). Microcontroller-Based pH and Turbidity Measuring System. *MATTER: International Journal of Science and Technology*, 4(2), 266-274

This work is licensed under the Creative Commons Attribution-Non Commercial 4.0 International License. To view a copy of this license, visit <http://creativecommons.org/licenses/by-nc/4.0/> or send a letter to Creative Commons, PO Box 1866, Mountain View, CA 94042, USA.

## **MICROCONTROLLER-BASED pH AND TURBIDITY MEASURING SYSTEM**

**Cho Cho Myint**

Department of Natural Science, University of Computer Studies, Mandalay, Myanmar  
[ccm.chochomyint.2016@gmail.com](mailto:ccm.chochomyint.2016@gmail.com)

**Dr. Maung Maung Soe**

Department of Physics, Mandalay University, Mandalay, Myanmar  
[maungsoemg@gmail.com](mailto:maungsoemg@gmail.com)

---

### **Abstract**

*Sustaining and monitoring appropriate pH levels is important in agricultural, industrial and environmental processes. For measurement of the pH level, it is essential to choose the correct pH probe. Turbidity can be measured by turbidity meters for the assessment of water quality or the proficiency of purification process.*

**Research Objectives:** *To investigate the water quality of streams and lakes, to measure various pH levels of liquids and to measure different turbidity values of liquids.*

**Methodology:** *The microcontroller based pH level and turbidity measuring system is designed and constructed using a pH probe -KADY pH tester / meter, amplifier circuit, turbidity sensor, PIC 16F887 microcontroller circuit, 16 x 2 line LCD module and power supply circuit.*

**Findings and Research outcomes:** *In pure water, pH is 5.5-6.9 and voltage is 700-720mV. In coca, pH is 2-3 and voltage is 620 – 640 mV. In salt water, pH is 9-10 and voltage is 780-800 mV.*

*In orange, turbidity is 300-900 NTU and voltage is 1.0V-0.7V. In coca, turbidity is 65-80 NTU and voltage is 1.4V – 1.58V. In milk, turbidity is >4000 NTU and voltage is 0-0.1 V.*

**Conclusion:** *The pH sensor circuit and turbidity sensor circuit can be assembled together with constructed microcontroller circuit.*

### **Keywords**

PIC16F887 Microcontroller, pH Sensor, Turbidity Sensor, Liquid

---

## **1. Introduction**

Water quality testing is an important part of environmental monitoring. Accurate pH measurement is required by adjusting the pH beforehand transport it to the community sewer system. Calibration powders enable to test the pH of pool, aquarium, water, and more quickly with pH tester / meter (“Definition of PH and PH Testing Tools,” n.d.).

Turbidity can provide nutrition and shelter for pathogens leading to waterborne disease outbreaks throughout the world (Wilde, F. D., & Gibs, J. (n.d.)). Therefore turbidity is very important for human health. It can be measured by a turbidity sensor.

## **2. The Block Diagram of the Whole System**

The block diagram of the constructed system is displayed in Figure 1. It consists of five main blocks; the pH sensor, turbidity sensor, microcontroller circuit, LCD module and power supply circuit. The pH sensor detects the pH level of a liquid and produces a small voltage. The voltage is amplified and sent to the microcontroller circuit. The turbidity sensor is used to measure the turbidity of a liquid. Measured data is sent to the microcontroller circuit. The microcontroller circuit processes on measured data and then sent to the LCD module. The power supply circuit is used to supply necessary voltages to other sections.

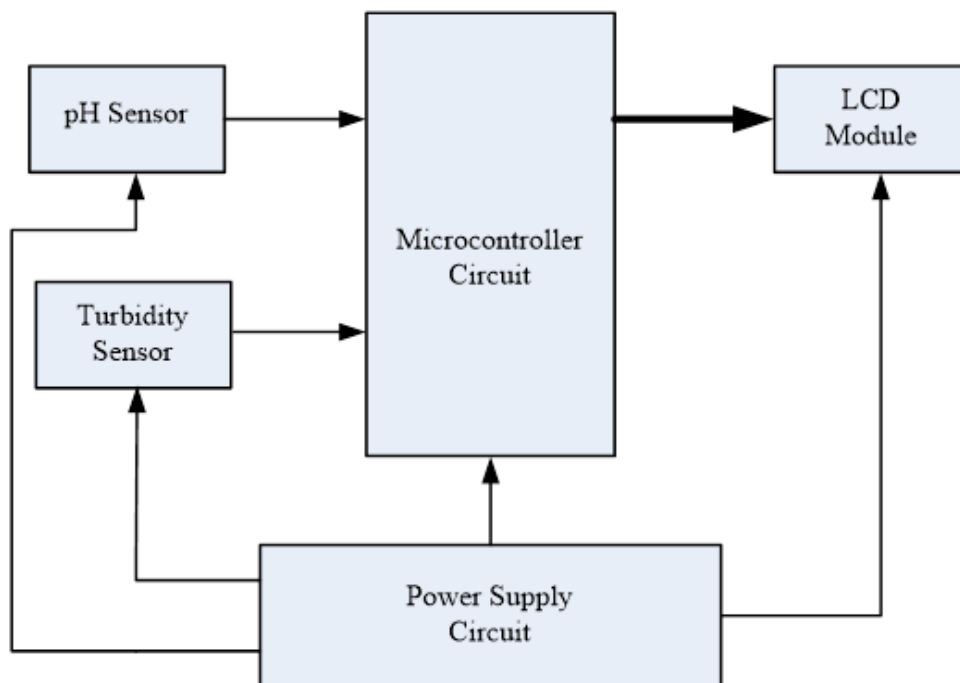

**Figure 1:** *The block diagram of the constructed system*

## 2.1 Turbidity Sensor

Turbidity is an optical characteristic which refers to the amount of clearness of a liquid. It is caused by individual suspended element or colloidal substance that scatters or blocks light diffusion: the higher the concentration of suspended elements/colloidal substances, the higher the turbidity (Wilde & Gibs, n.d.). It is measured in Nephelometer or turbidity meter and its unit is Nephelometric Turbidity Unit (NTU). The World Health Organization mentions that the turbidity of drinking water should not be more than 5 NTU.

Turbidity meters are used for the assessment of water quality. Since turbidity not only influences the yield of the manufacturing process but also distinguish factors which are disadvantageous to a system, its measurements are significant indicators in many works. The turbidity sensor circuit comprises of two main parts - an emitter and a detector. The sensor quantifies the degree of light scattering which is determined by suspended elements in a liquid medium.



**Figure 2:** *Turbidity sensor and amplifier circuit*

## 2.2 The pH Probe

The pH probe is an essential component in the measurement of the pH level (“PH Electrode Probe BNC Connector for Aquarium PH Control Meter Sensor,” 2016). It is important to choose the correct pH probe for optimal pH measurement (Lawn & Prichard, 2003). The most important standards are: chemical composition, homogeneity, temperature, process pressure, pH range and container size. The pH probe (Riddle, 2013) used in this research work is displayed in Figure 3.



**Figure 3:** *The pH electrode probe with BNC connector*

### 3. PIC16F887 Microcontroller

PIC16F887 microcontroller is basically a computer on a chip. It is one of the most important developments in electronics and needed for the process of devices such as mobile phones, DVD players, video cameras, and most self-contained electronic systems(Huang, 2005). Microcontrollers contain all the components required for a processor system in one chip: a CPU, memory and input, output. A complete system can be built using one Micro Controller Unit (MCU) chip and a few input, output device such as a keypad, display and other interfacing circuits (Bates, 2013).

PIC16F887 chip can be found in different packages, 40-pin Dual In-Line Package (DIP), square surface mount or socket format. It is the 14-bit instruction word mid-range microcontroller from the Microchip Technology. The PIC microcontroller architecture is based on Reduced Instruction Set Computer (RISC) instruction set (Ibrahim, 2006). The PIC16F887 is a 40-pin device and is one of the popular microcontrollers used in complex applications. The pin structure of the PIC16F887 microcontroller(Ibrahim, 2008) is displayed in Figure 4.

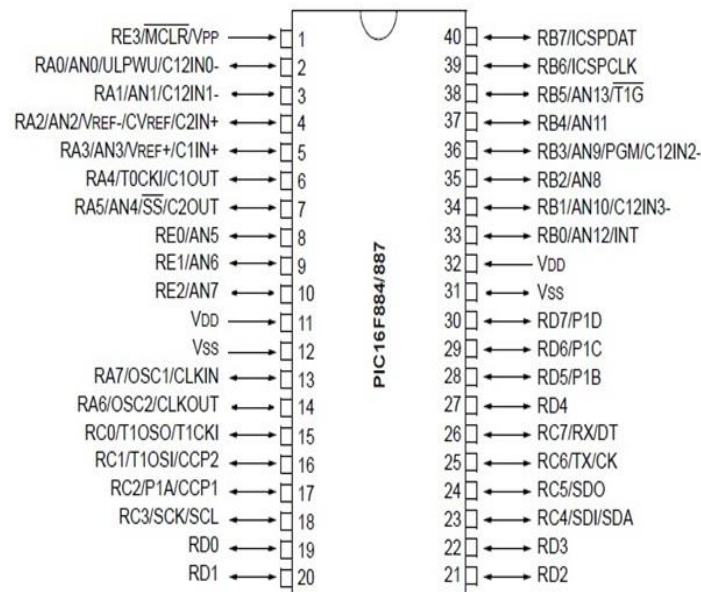

Figure 4: The pin structure of the PIC16F887 microcontroller

#### 3.1 System Software

In this project two types of software are used.

- Software for micro c programming
- LABVIEW

### 3.2 Liquid Crystal Display (LCD)

Liquid Crystal Displays are alphanumeric displays which are normally used in microcontroller-based applications. LCDs are model in low-power, battery- operated portable applications. There are two types of LCDs: parallel LCDs and serial LCDs. Parallel LCDs are connected to the microcontroller I/O ports using 4 or 8 data wires and data is transferred from the microcontroller to the LCD in parallel form. These modules has built-in controller, driver, character generator RAM/ROM. It is capable of displaying two lines of 16 characters. The LCD module provides 4-bit or 8-bit parallel interfaces and writes data directly. The LCD module follows to standard eight-data lines, three control lines and five power lines. The connections are laid out a single row of 16 pins. Pin 1 and Pin 2 are the power supply lines,  $V_{SS}$  and  $V_{DD}$ . The  $V_{DD}$  pin is connected to the positive supply and  $V_{SS}$  to the 0V supply or ground.  $V_{EE}$  or  $V_0$  used to adjust the contrast of the display. Ideally this pin connected to a various resistor. The pin description of the 16 x 2 line LCD module is shown in Figure 5.

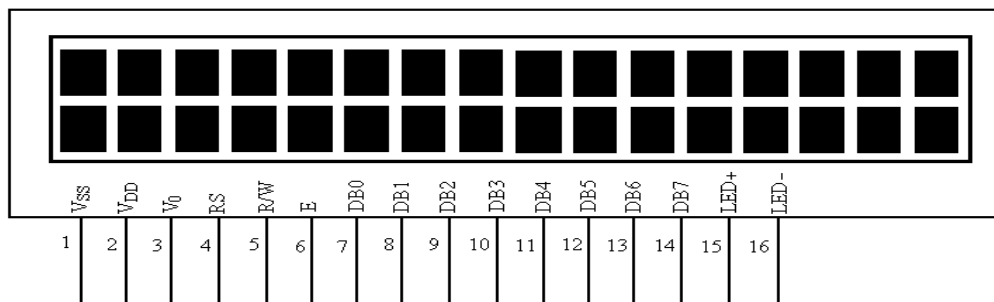

Figure 5: The pin description of the 16 x 2 line LCD module

### 4. Construction and Operation of the System

Microcontroller based turbidity measuring circuit is designed and constructed using an optical turbidity sensor, amplifier circuit, PIC 16F887 microcontroller circuit, 16 x 2 line LCD module and power supply circuit. The turbidity sensor is the opto-isolator circuit. It consists of IR LED and photo transistors connected as Darlington pair separating about 1 cm. The opto-isolator is embedded in the water proof plastic cave. The IR LED produces IR light to the photo transistors.

The liquid between the IR LED and photo transistors causes the reduction of light intensity according to the turbidity of the liquid. The photo transistor conducts the current

through its collector emitter junction and then develops voltage across the resistor which is connected to the emitter and ground terminal. The voltage depends on the turbidity of the liquid. The more voltage is produced when the liquid is clear due to the less loss in IR light passing through it. The output of the sensor is fed to the amplifier to obtain appropriate voltage gain.

The output of the amplifier circuit is attached to the analog input of the microcontroller circuit. The analog voltage is converted into corresponding turbidity values in NTU unit. The measured turbidity result is sent to the LCD module and displayed on the screen. The whole circuit diagram for the turbidity measurement is displayed in Figure 6.

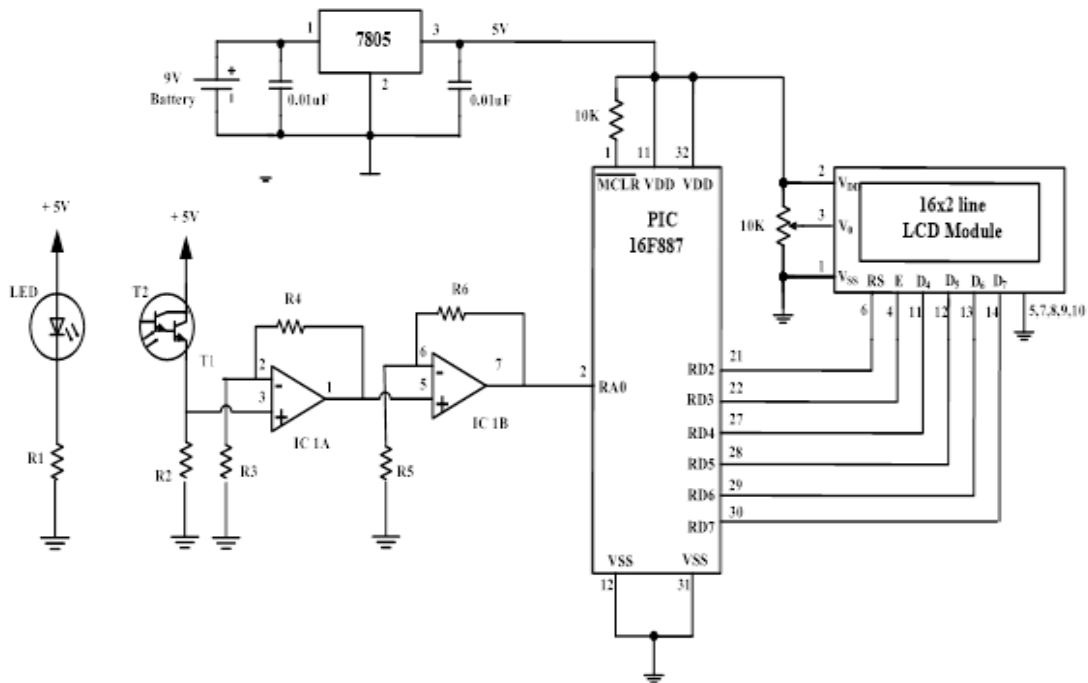

Figure 6: The whole circuit diagram for the turbidity measurement

## 5. Result and Discussion

The pH measurement is founded on the use of a pH sensitive electrode. Isopotential point is commonly designed to be at 7.0 pH and at 0 mV. Turbidity measurement is built on the use of a turbidity sensor (opto isolator) as displayed in figure 7. In water, turbidity sensor reading is between 0.05 NTU and 10 NTU. Voltage signal reading is from 1.33V to 1.61V. In coca, turbidity sensor reading is between 65 NTU and 80 NTU. Voltage signal reading is from 1.4V to 1.58V. In orange, turbidity sensor reading is between 300 NTU and 900 NTU. Voltage signal



reading is between 0.7V and 1V. In milk, turbidity sensor reading is less than 4000 NTU and voltage signal reading is nearly 0V.

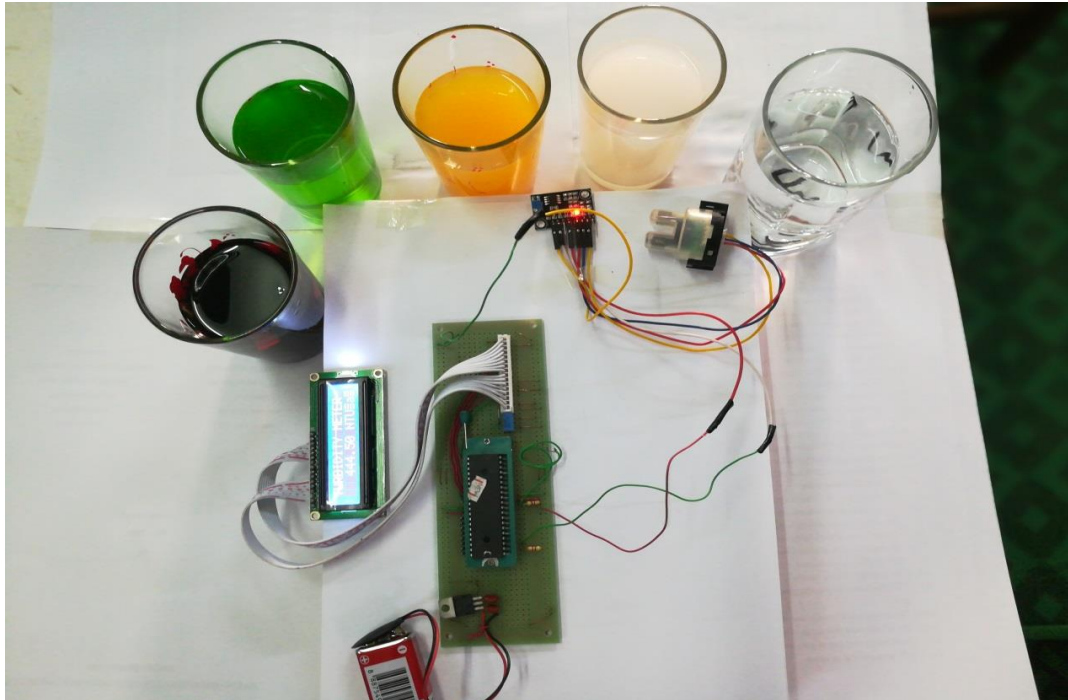

**Figure 7:** *The photograph showing the turbidity measuring circuit and various sample liquids*

## 6. Conclusion

The pH sensor circuit and turbidity sensor circuit can be assembled together with the constructed microcontroller circuit. The PC interface circuit can also be implemented to monitor the measured quantities of the liquid in graphical form. (e.g. Lab VIEW). Moreover the other quantities of liquid (e.g. water) such as conductivity, salinity can be attempted to measure by using Lab make sensors.

## 7. Future Plan

The pH sensor circuit, temperature sensor circuit and turbidity sensor circuit will be assembled together with constructed microcontroller circuit. The PC interface circuit will also be constructed to monitor the measured quantities of the liquid in graphical form. Moreover the other quantities of liquid (e.g. water) such as conductivity, salinity will be attempted to measure by using off-the-shaft sensors or Lab make sensors.



## References

- Bates, M. P. (2013). *Interfacing PIC Microcontrollers: Embedded Design by Interactive Simulation* (2nd Edition). Newnes. Retrieved from <https://books.google.com/books?isbn=0080993729>
- Definition of PH and PH Testing Tools. (n.d.). Retrieved from <http://www.benmeadows.com>
- Huang, H.-W. (2005). *PIC Microcontroller: An Introduction to Software and Hardware Interfacing* (1st Edition). Cengage Learning.
- Ibrahim, D. (2006). *PIC BASIC PROJECTS: 30 Project Using PIC BASIC and PIC BASIC PRO*. UK: Elsevier's Science & Technology. <https://doi.org/10.1016/B978-075066879-8/50000-7><https://doi.org/10.1016/B978-075066879-8/50004-4> <https://doi.org/10.1016/B978-075066879-8/50002-0> <https://doi.org/10.1016/B978-075066879-8/50005-6> <https://doi.org/10.1016/B978-075066879-8/50001-9> <https://doi.org/10.1016/B978-075066879-8/50003-2>
- Ibrahim, D. (2008). *Advanced PIC Microcontroller Project in C* (First Edition).
- Lawn, R., & Prichard, E. (2003). *Measurement of PH*. Royal Society of Chemistry.
- Riddle, P. (2013). pH meter and their electrodes :calibration, maintenance and use, 202–205.
- Wilde, F. D., & Gibs, J. (n.d.). Turbidity. In U.S. Geological Survey TWRI Book. CRC Press Taylor& Franics Group. Retrieved from <https://water.usgs.gov/owq/FieldManual/Chapter6/Archive/6.7/Section6.7.pdf>